

B350TLA LED Traffic Light

The B350 series of traffic light beacons are available in single E14 filament bulb or high output L.E.D array versions. The compact housing is ideal for space constrained applications or for mounting directly onto machinery.

Multiple B350 traffic light beacons can be assembled into a stack utilising the supplied connector and can also be combined with the B300SND alarm horn sounder for a complete audio-visual signalling solution.

Features

- Bayonet fixing lens.
- Anti-tamper locking screw.
- Stainless steel fixings.
- Unit is supplied with a clear prismatic lens to optimise visibility in applications with high ambient light levels.

Approvals

- GOST-R certificate: POCC GB.JB05.H00144.



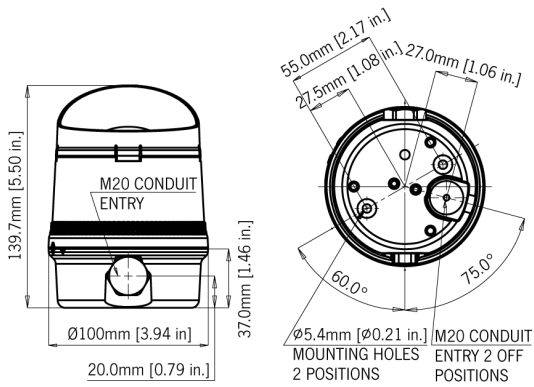

Specification

Light source:	High output L.E.D.
Light output:	15 x L.E.D. array
Function:	Permanent
L.E.D. colours:	Amber, Blue, Green, Red, White
Peak/Effective Intensity cd:	54 cd* - measured ref. to I.E.S.
Lens type:	Prismatic
Mounting:	Surface mount (Wall mount bracket available)
Entries:	1 x 5-7mm push through grommet 1 x M20 cable entry
Dimensions:	ø100 x 140mm
Ingress protection:	IP65
Housing material:	High impact UL94 V0 (f1) PC
Terminals:	0.5 to 1.5mm ²
Operating temp:	-25 to +50°C [-13° to +122°F]
Storage temp:	-40 to +70°C [-40° to +158°F]
Relative humidity:	90% at 20°C [68°F]
Weight:	350g/0.77lbs

Part Codes

|_Version: |_.Part code: | |10-30V dc | B350TLA030B/[x] | |90-230V ac
50/60Hz | B350TLA230B/[x] | [x] = Lens colour: |A: Amber

B: Blue

G: Green

R: Red

W: White | |2.Note: B350TLA units are supplied with 'clear' lenses to maximise the light output in environments with high ambient light levels. | |_.Mounting brackets: |_.Description: | |MB-B350T-S| Mounting bracket kit for a single B350 type unit. | |MB-B350T-M| Mounting bracket kit for linked multiple B350 type units | |2.Note: Multiple unit connector is supplied with each product. |

Current Consumption

Version:	Current mA:
Version:	Current mA:
10-30V dc	110mA
90-230V ac	50/60Hz 10-30mA