

L101X

5 Joule Xenon

The L101X is a compact, robust 5 Joule Xenon strobe beacon ideal for all general signalling applications including fire, security and process control. CPR compliant, approved to EN54-23:2010 for use in fire alarm systems, the L101X also carries GOST approval and cULs approval for general signalling.

Featuring an automatically synchronised flash rate of 1Hz (60 flashes per minute) as standard, the DC voltage versions also have user selectable 1.5Hz (90 flashes per minute) and double-strike flash rates.

General:

Ingress Protection:	IP66
Housing material:	UL94V0 & 5VA FR ABS
Housing colour:	RAL3000 Red, RAL7038 Grey and White
Lens material:	PC
Fixings:	Stainless Steel
Operating temp:	-25° to +55°C
Storage temp:	-40° to +70°C
Relative humidity:	90% at 20°C
Weight :	0.20kg

Specification:

Energy:	5 Joules (5Ws)
Flash rate:	1Hz (60 fpm)
	DC units: Optionally 1.5Hz & double strike
Peak Candela:	86,935 cd
Effective Intensity cd:	200 cd*
Terminals:	0.5 to 4.0mm ² cables.
Lens colours:	Amber, Blue, Clear, Green, Red, Yellow
Tube life :	Emissions are reduced to 70% after 8 million flashes

Features:

- Back boxes available with and without mounting lugs.
- Pluggable terminals.
- In and out terminals.
- Multiple, user selectable flash rates.
- User replaceable Xenon tube lamp.
- Tropicalisation available on request.
- Can be stacked to create multi-signal units.
- Can be combined with AlertAlarm & Sonora audible signals.

Approvals:

- CPD approval: 0786-CPD-21247 to EN54-23:2010.
- VdS certificate: G211077 (24 & 48Vdc versions).
- UL approved version available (non-fire alarm use).
- GOST-R certificate: POCC GB.JB05.H00144.



0786-CPD-21247



Multi-purpose type back box

A100 type back box

Sonora type back box

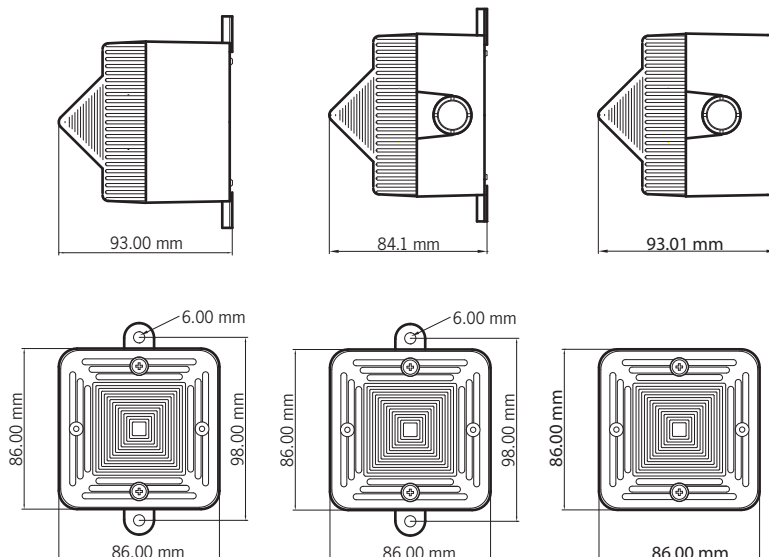

L101X standard back box

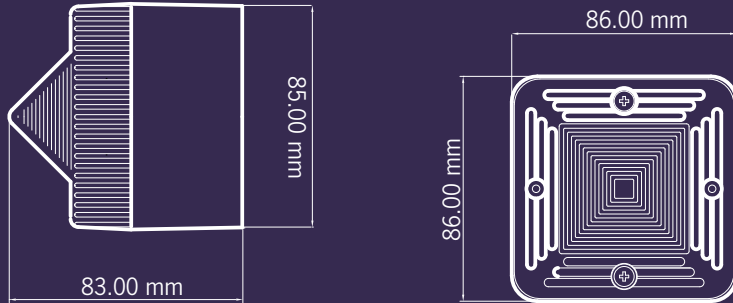

Unit:	Cat. C	Cat. W	Cat. O	Power
	[Ceiling]	[Wall]	[Open]	
L101XDC024[b][x]/C	C-9-6.8 V=326.9m ³	W-2.4-4.8 V=55.3m ³	O-4.8-10 V=230.4m ³	6W
L101XDC024[b][x]/R	C-9-6.8 V=15.9m ³	n/a n/a	O-1.9-3.6 V=13.0m ³	6W
L101XDC048[b][x]/C	C-9-7 V=346.4m ³	W-2.5-5 V=62.5m ³	O-5-10 V=250.0m ³	8.4W
L101XDC048[b][x]/R	C-3-3 V=21.2m ³	n/a n/a	O-2-4 V=16.0m ³	8.4W

L101X Strobe Beacon:

Version:	Voltage range:	Current mA:	Part Code:
12V dc/ac	10-14V	500mA/380mA	L101XDC012[b][x]/[y]
24V dc/ac	20-28V	250mA/300mA	L101XDC024[b][x]/[y]
48V dc	42-52V	175mA	L101XDC048[b][x]/[y]
48V ac	+/-10%	250mA	L101XA0C48[b][x]/[y]
115V ac	+/-10%	70mA	L101XAC115[b][x]/[y]
230V ac	+/-10%	35mA	L101XAC230[b][x]/[y]

Part codes:

[b] = Back box type: B: standard L101 type A: A100 type,
M: Multi-purpose type S: Sonora type

[x] = Housing colour: G: Grey, R: Red, W: White

[y] = Lens colour: A: Amber, B: Blue, C: Clear, G: Green, R: Red, Y: Yellow

Suffix part number with '-UL' for UL approved version (M: Multi-purpose back box version only).

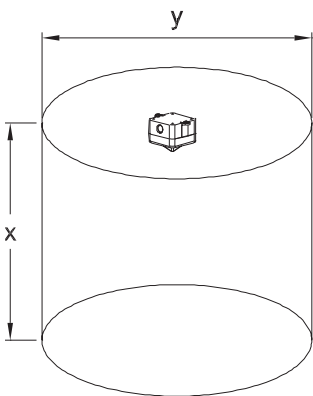

Category C-x-y (Ceiling mounted):

- Ceiling mounted, where **x** is the maximum ceiling height and **y** the diameter of the cylindrical volume covered by the VAD.

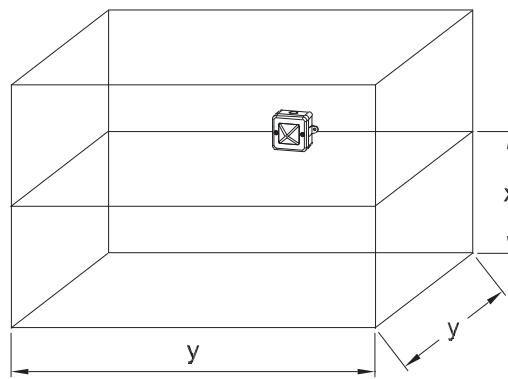

Category W-x-y (Wall mounted):

- Wall mounted, where **x** is the maximum mounting height from the floor and **y** is the maximum length of the sides of the square floor area covered by the VAD.

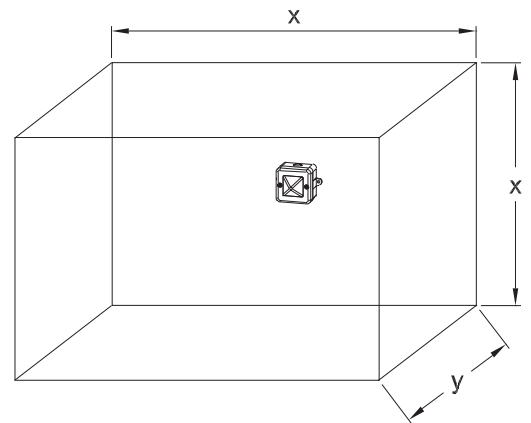

Category O-x-y (Open class):

- Centrally wall mounted, where **x** is the max height and width of the wall area covered by the VAD and **y** is the max depth of the volume covered by the VAD. Or ceiling mounted where **x** is the max width and length of the floor area covered by the VAD and **y** is the max ceiling height.