

CR-X Compound-Filled Cable Gland – ASSEMBLY INSTRUCTIONS FOR SAFE USE**

Brief Description

The Peppers CR-X** type Compound-filled cable gland is for outdoor use in the appropriate Hazardous Areas with unarmoured cable of any construction, with or without braids or screens, where the braids or screens pass through the compound. It may also be used as a line bushing for terminating flying leads or for the direct inter-connection of associated enclosures. A variant giving electrical continuity to a lead sheath is available. It gives environmental protection to IP66, IP68 and Deluge.



Warning

PLEASE STUDY CAREFULLY BOTH PAGES OF THESE INSTRUCTIONS BEFORE INSTALLATION. These glands should not be used in any application other than those mentioned here or in our Data Sheets, unless Peppers states in writing that the product is suitable for such application. Peppers can take no responsibility for any damage, injury or other consequential loss caused where the glands are not installed or used according to these instructions. This leaflet is not intended to advise on the selection of cable glands. Further guidance can be found in the standards listed overleaf.

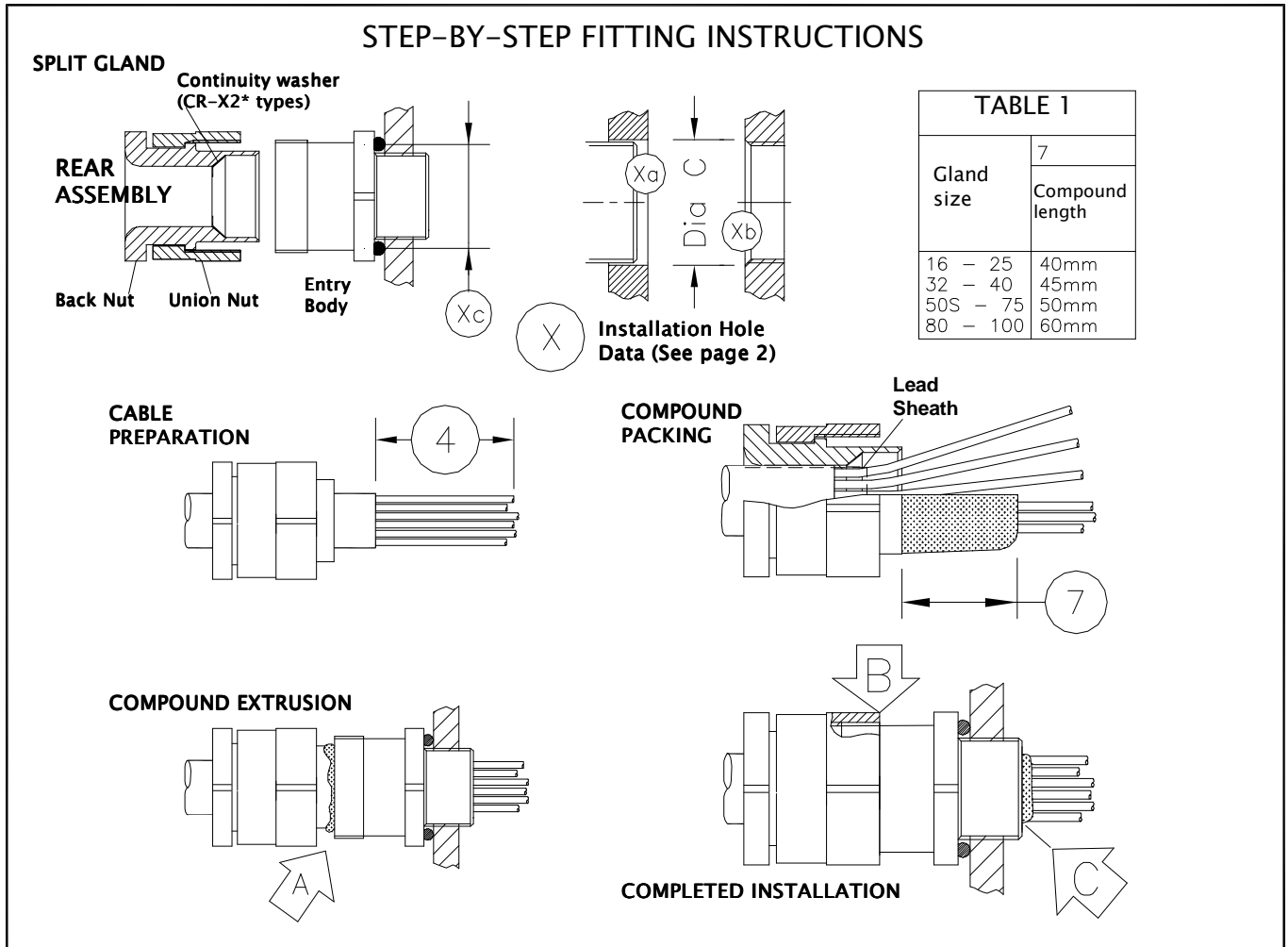

STEP-BY-STEP FITTING INSTRUCTIONS

- 1 Split gland as shown
- 2 Fit Entry Body. Hand-tighten, then using wrench tighten a further ½ turn. DO NOT EXCEED MAX TORQUE FOR ENCLOSURE
- 3 Slide Rear onto cable as shown
- 4 **CABLE PREPARATION**
Strip jacket so that cores are fully exposed in the compound chamber, length to suit installation. Lead sheath must be cut to push through the continuity washer. Remove protective foils, and any cords/fillers from around and between the cores. Take care not to cut the insulating sleeves of the cores. Pigtail and sleeve any screens to be passed through compound.

HEALTH AND SAFETY WARNING The resin used in the compound can cause eye and skin irritation. For your personal protection, wear the gloves supplied while mixing and applying. The uncured compound should not be allowed to come into contact with foodstuffs.
A COMPREHENSIVE SAFETY DATA SHEET PROVIDED BY THE COMPOUND MANUFACTURER IS AVAILABLE ON REQUEST

- 5 Check compound has not passed its "Use By" date. Installation at temperatures below 10° C should be avoided.
- 6 Trim any hardened pieces from ends of stick. Mix the compound by rolling, folding and breaking. Ease mixing by cutting large sticks in half. Fully mixed compound has a uniform yellow colour with no streaks.
- 7 Support the cable and Rear Assembly, holding them roughly concentric. Any lead sheath is pushed through the continuity washer - ensure that contact has been made. Splay out the cores. Starting at the middle, pack small amounts of rolled-out compound between the cores. Re-straighten each core and work outwards until all gaps are filled. Bundle the cores with cord or tape so they are not disturbed. Pack around the outside of the outer cores to completely fill the Rear Assembly cup. Build up compound around the outside of the cores, with a slight taper & to approximate compound length shown in diagram & Table 1 column 7
- 8 Pass cores through & push compound into Entry Body until Rear Assembly engages. Remove squeezed out compound at arrow A. Support the Back Nut and screw Union Nut 7 full turns onto Entry Body (arrow B). Ensure that compound emerges at entry thread (arrow C)
- 9 Clean off excess compound from Entry Body to allow withdrawal when cured (arrow C). Cores may be disturbed after 1 hour. Leave to cure for 4 hours when working at 21° C

CR-X Compound-Filled Cable Gland – ASSEMBLY INSTRUCTIONS FOR SAFE USE**

- 10 To release and pull back joint for inspection, unscrew Union Nut
- 11 Hand-tighten Union Nut to remake joint. Then refer to table below and tighten using wrench to the given amount
- 12 The equipment should not be energised until the compound has been left to cure for at least 4 hours when working at 21° C. See chart 'Energising Time vs. Temperature' for further guidance

X INSTALLATION HOLE DATA (See below)

- Xa** Diameter for clearance holes (NOT Ex d)
- Xb** Diameter of countersink for threaded holes (Ex d) **Xc** Diameter of O-ring seat

Wrench tightening information (Instruction 11), cable sizes (mm) & permitted cores

X Hole data		Gland Size	Tighten Union Nut using wrench up to	Max Diameter over Cores	Max No of Cores	Outer Sheath Max
Xc	Xa / Xb					
22.2	20.5	20S	½-turn	10.4	35	11.7
22.2	20.5	20	½-turn	12.5	40	14.0
27.9	25.5	25	½-turn	17.8	60	20.0
35.5	32.5	32	½-turn	23.5	80	26.3
43.5	40.5	40	½-turn	28.8	130	32.2
53.5	50.5	50	½-turn	39.4	400	44.1
66.5	63.5	63	½-turn	50.0	425	56.0
78.5	75.5	75	½-turn	60.8	425	68.0
83.5	80.5	80	¾-turn	64.4	425	72.0
88.5	85.5	85	¾-turn	69.8	425	78.0
93.5	90.5	90	¾-turn	75.1	425	84.0
103.5	100.5	100	¾-turn	80.5	425	90.0

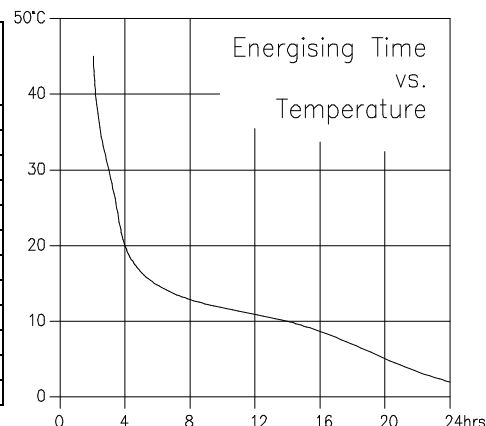

Installation Guidance

Point	Advice
1	<ul style="list-style-type: none"> ◆ BS EN 60079-10 Classification of Hazardous Areas ◆ BS EN 60079-14 Electrical Installations in hazardous areas (other than mines) ◆ BS 6121, Part 5 Selection, Installation and Maintenance of Cable Glands ◆ IEC 60079-31: 2008 Ignitable dust – Protection by enclosure
2	Installation should only be carried out by a competent electrician, skilled in cable gland installation.
3	NO INSTALLATION SHOULD BE CARRIED OUT UNDER LIVE CONDITIONS.
4	To maintain Ingress Protection ratings above IP64, use IP washers or O-rings for parallel threads. For taper threads use thread sealant. Also see page 1 diagram and Hole Data above.
5	To ensure the stated IP rating is maintained, at the point of interface the surface of the enclosure should be flat, free from debris and rigid with the hole drilled straight and to an appropriate diameter.
6	Where an earth contact is required the surface of the enclosure should be sufficiently flat and rigid. With painted enclosures a serrated star washer should be fitted to break through the paint and make a satisfactory earth contact.
7	Once installed do not dismantle except for routine inspection. A detailed inspection should be conducted as per IEC/EN 60079-17. After inspection the gland should be re-assembled as detailed in point 11, ensuring the Mid Cap if fully tightened.
8	Parts are not interchangeable with any other design. If manufacturers' parts are mixed, certification will be invalidated. The gland is not serviceable and spare parts are not supplied.

Limitations on Usage. Be sure your installation complies with the following:-

Feature	Comment
Enclosure entry thread	The female thread in the enclosure must comply with clause 5.3 of IEC/EN 60079-1. Do not damage threads on assembly. Check that the number of fully engaged threads is at least 5.

Interpretation of Markings. Markings on the outside of this gland carry the following meanings:

Cable Gland Type & Size CR-X-2-a-bbb-ccc-IP66 / IP68-nn; where: -

- 2 =** Continuity washer option for lead sheathed cable
- a =** Main component material **B =** brass **S =** stainless steel
- bbb =** Gland size
- ccc =** Entry thread type and size
- IP66 / IP68 =** Ingress Protection code
- nn =** Year of manufacture

Protection Concept, EPL's and Gas Groups: Ex d I&IIC Exe I&IIC Mb Gb / Ex ta IIIC Da / Ex nR IIC Gc

Environmental Protection: IP66 / IP68 (100 metres for 7 Days)

Certificate Numbers: (ATEX) **SIRA 03ATEX1479X / SIR09ATEX4124X** (CSA) **1356011**
(IEC) **IECEx SIR 07.0098X** (GOST-R) **POCC GB.ГБ06.В00853**

ATEX (EU Directive 94/9/EC) Markings: I M2 II 2 GD II 3 GD

GOST-R Approval: ExdIU / ExdIIICU / ExelU / ExelIU / ExnRIIU
CSA Approval: Exd IIC / Exe II / CL I Div 2 Gr ABCD, CL II Gr EFG, CL III Type 4X

Special Conditions for Safe Use

1. The cable glands shall not be used in enclosures where the temperature, at the point of mounting, is outside the range of -60°C to +135°C.
2. The entry component threads will be suitably sealed using a method that is applicable to the associated equipment to which the gland will be attached. This will be in accordance with the relevant installation code of practice and will ensure that any ingress protection and restricted breathing sealing requirements are maintained.
3. When glands without sealing rings are installed in an explosive dust atmosphere, they shall only be fitted into enclosures that have entries that will ensure that a minimum of 5 full threads of contact will be maintained, this is in accordance with clause 5.1.1 of IEC 60079-31:2008.