

SPECTRA B200STR

Xenon Strobe Flashing Beacon

1 J @ 0.75Hz

IP Rating: IP65

Temp: -25°C to +50°C

Unit weight: 84g DC, 89g AC
CE

Dimensions : Ø60 x 80mm

2.5mm² terminals

Cable entry: 1 x 5-7mm push through
grommet

x = Lens colour

R = Red

B = Blue

Y = Yellow

A = Amber

G = Green

C = Clear

Voltage

B200STR030B/x 10-30V DC 135mA

B200STR115B/x 115V AC 30mA

B200STR230B/x 230V AC 25mA

Mountings

B200RAB001 Right angle bracket

B200TMA001 Tube mounting assembly

Tel : +44 (0)20 8743 8880 Fax : +44 (0)20 8740 4200

email : sales@e2s.com web : www.e2s.com



 **ATTENTION:** Installation must be carried out by an electrician in compliance with the latest codes and regulations.

 **ATTENTION:** Disconnect from power source before installation or service to prevent electric shock.

 **ATTENTION:** On strobe beacons allow a minimum of 2 minutes for hazardous high voltage to discharge from unit.

 **ATTENTION:** Lens on unit will be hot allow to cool prior to removal.



A SPECIIRA B200STR

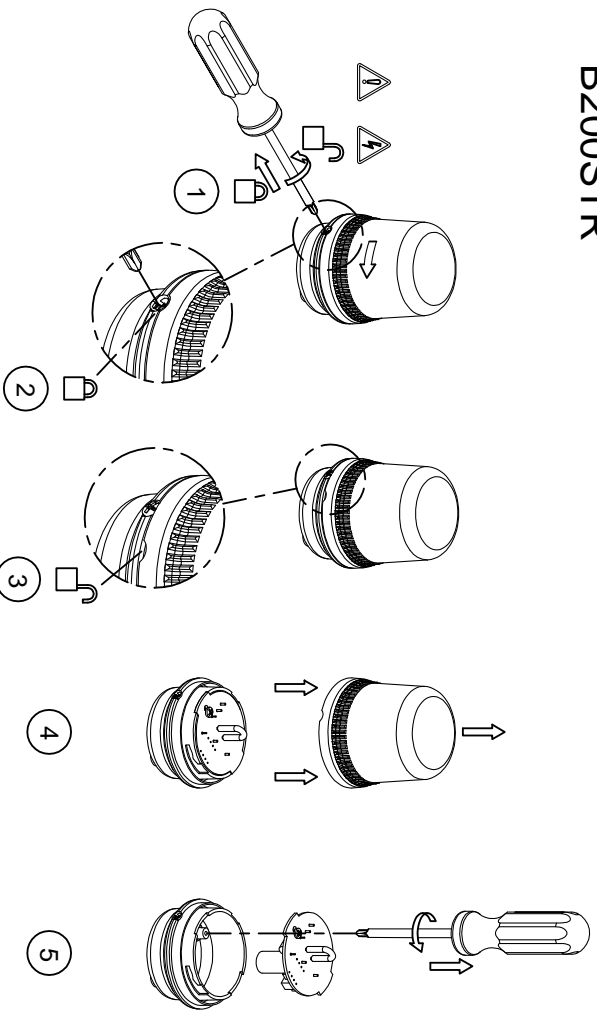

Tel : +44 (0)20 8743 8880 Fax : +44 (0)20 8740 4200
 Mail : sales@e2s.com Web : www.e2s.com



MOUNTING OPTIONS	
a	STANDARD BASE
b	POLE MOUNT
c	90° BRACKET

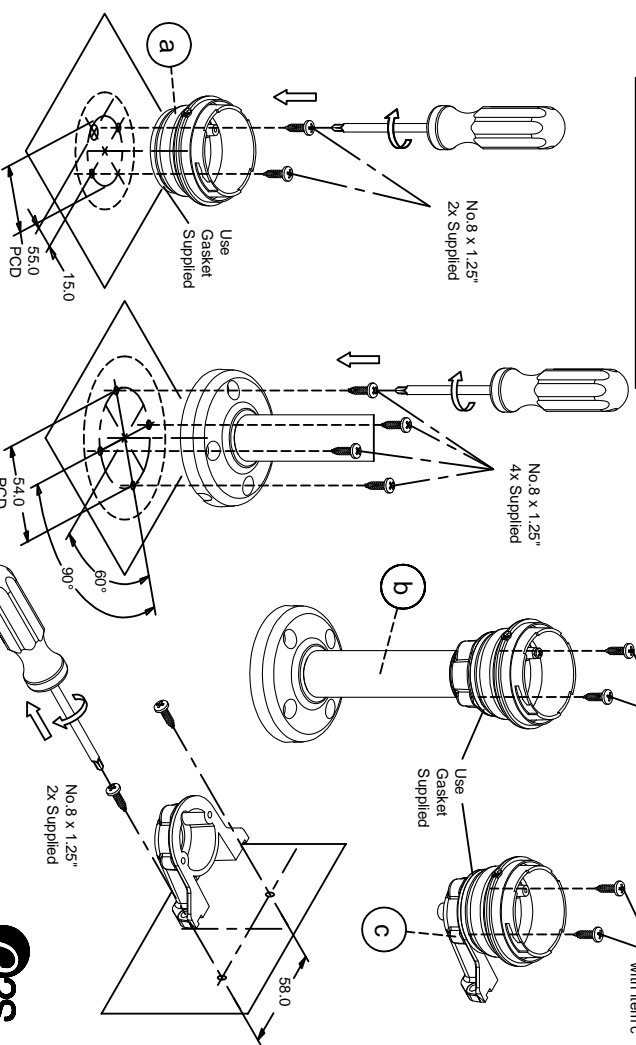

Dimensions in mm

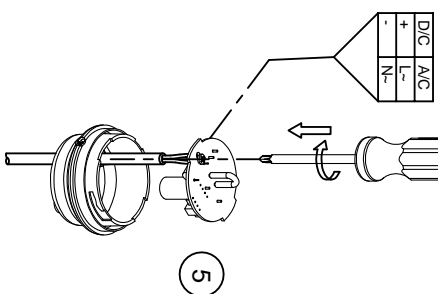
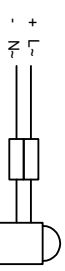
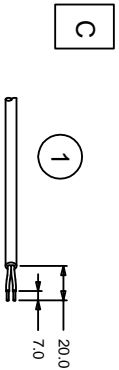

D102-00-001-HS-SHTZ-ISSUE_B