

Brief Description

Peppers A*LDS*F type cable glands are for outdoor use in the appropriate Hazardous Areas with unarmoured, braided or armoured cable, where the braid or armour is to be terminated inside the enclosure. They seal on the outer jacket, and give environmental protection to IP68.



Warning

PLEASE STUDY CAREFULLY BOTH PAGES OF THESE INSTRUCTIONS BEFORE INSTALLATION. These glands should not be used in any application other than those mentioned here, unless Peppers states in writing that the product is suitable for such application. Peppers can take no responsibility for any damage, injury or other consequential loss caused where the glands are not installed or used according to these instructions. This leaflet is not intended to advise on the selection of cable glands. Further guidance can be found in the standards listed overleaf.

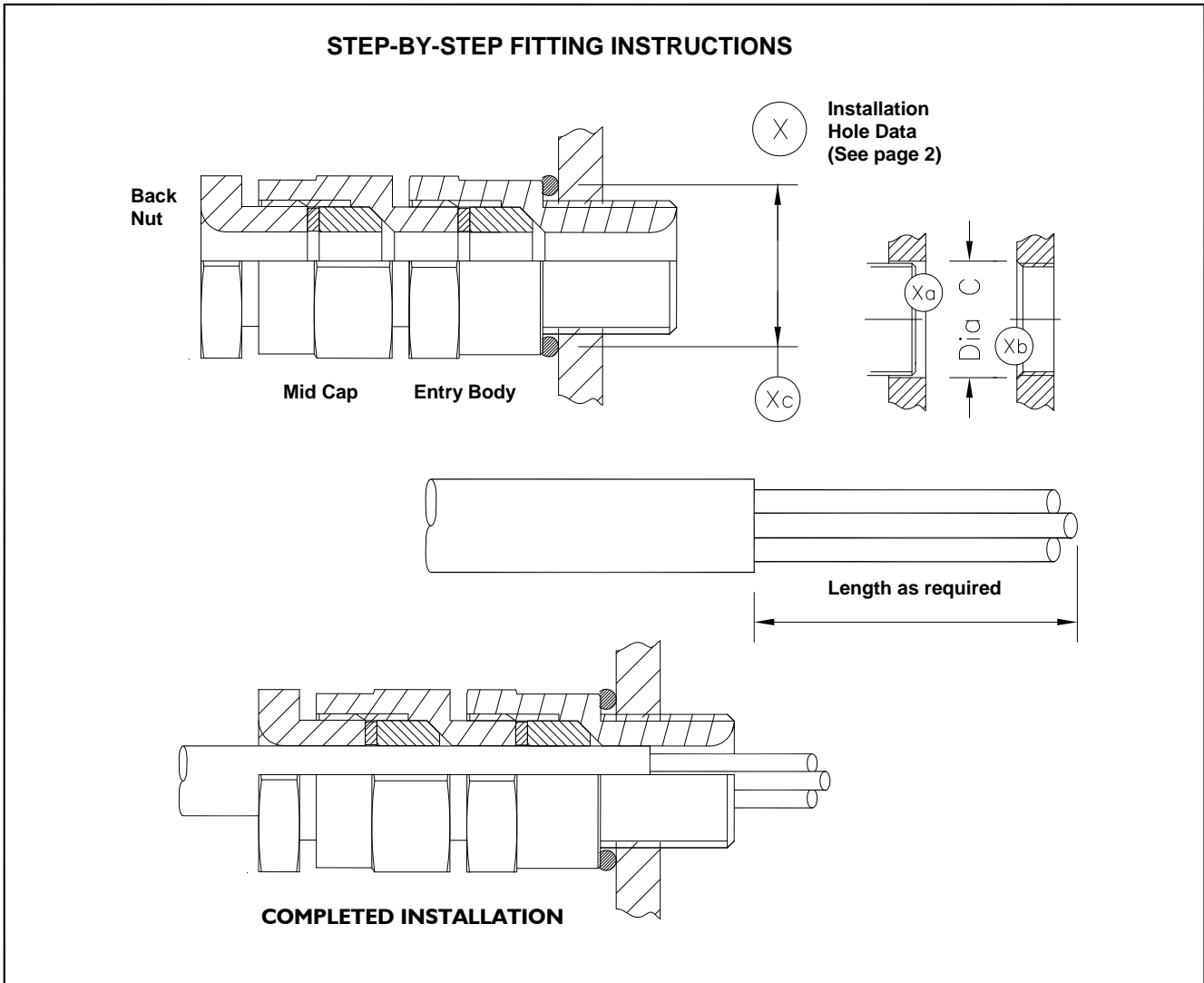

STEP-BY-STEP FITTING INSTRUCTIONS

- 1 Check there is no tension in the threads.
- 2 Fit the complete cable gland to the enclosure. Hand-tighten, then using wrench tighten a further ½ turn. **DO NOT EXCEED MAX TORQUE FOR ENCLOSURE THREAD.**
- 3 Prepare cable as required.
- 4 Insert cable through cable gland. Position the cable correctly. **BOTH** seals must grip the outer jacket of the cable when the cable gland is tightened.
- 5 Tighten Mid Cap to Entry Body. Ensure seal makes full contact with cable sheath. Tighten an extra 1½ turns (up to 2½ turns for minimum cable).
- 6 Tighten Back Nut to Mid Cap. Ensure seal makes full contact with cable sheath. Tighten one extra turn.

X INSTALLATION HOLE DATA (See page 2).

- Xa** Diameter for clearance holes (NOT Ex d).
- Xb** Diameter of countersink for threaded holes (Ex d).
- Xc** Diameter of O-ring seat.

Cable Sizes and entry hole data (mm)

X Hole data (see overleaf)		Gland Size	Outer Sheath	
Dia Xc	Dia Xa/Xb		Min	Max
22.2	20.5	16	4.0	8.4
22.2	20.5	20S	7.2	11.7
22.2	20.5	20	9.6	14.0
27.9	25.5	25	13.5	20.0
35.5	32.5	32	19.5	26.3
43.5	40.5	40	23.0	32.2
53.5	50.5	50S	28.2	38.2
53.5	50.5	50	33.2	44.1
66.5	63.5	63S	39.3	50.1
66.5	63.5	63	46.7	56.0
78.5	75.5	75S	52.3	62.0
78.5	75.5	75	58.1	68.0
83.5	80.5	80	62.3	72.0
88.5	85.5	85	69.1	78.0
93.5	90.5	90	74.1	84.0
103.5	100.5	100	82.1	90.0

Installation Guidance

Point	Advice
1	<ul style="list-style-type: none"> ◆ BS EN 60079-10 Classification of Hazardous Areas ◆ BS EN 60079-14 Electrical Installations in hazardous areas (other than mines) ◆ BS 6121, Part 5 Selection, Installation and Maintenance of Cable Glands ◆ IEC 61241-0:2006 and IEC 61241-1:2004 Ignitable dust – Protection by enclosure
2	Installation should only be carried out by a competent electrician, skilled in cable gland installation.
3	NO INSTALLATION SHOULD BE CARRIED OUT UNDER LIVE CONDITIONS.
4	To maintain Ingress Protection ratings above IP54, use IP washers or O-rings for parallel threads. For taper threads use thread sealant. Also see page 1 diagram and Hole Data above.
5	To ensure the stated IP rating is maintained, at the point of interface the surface of the enclosure should be flat, free from debris and rigid with the hole drilled straight and to an appropriate diameter.
6	Where an earth contact is required the surface of the enclosure should be sufficiently flat and rigid. With painted enclosures a serrated star washer should be fitted to break through the paint and make a satisfactory earth contact.
7	Once installed do not dismantle except for occasional inspection. If necessary, dismantle by reversing the instructions on page 1. The gland is not serviceable and spare parts are not supplied.
8	Parts are not interchangeable with any other design. If manufacturers' parts are mixed, certification will be invalidated.

Limitations on Usage. Be sure your installation complies with the following:-

Feature	Comment																									
Enclosure entry thread	The female thread in the enclosure must comply with clause 5.3 of IEC/EN 60079-1. Do not damage threads on assembly. Check that the number of fully engaged threads is at least 5.																									
Cable construction	The glands should only be used with substantially round and compact cables with extruded bedding (i.e. effectively filled cables).																									
EExe/Exe enclosures	If A*LDS*F glands are used in a non-metallic increased safety enclosure, they must be included in the earth circuit of the system.																									
Installation conditions	<table border="1" style="width: 100%; border-collapse: collapse;"> <thead> <tr> <th>Gas Group?</th> <th>Internal Ignition Source?</th> <th>Enclosure Volume?</th> <th>Which Zone?</th> <th>Use Type A*LDS*F Gland?</th> </tr> </thead> <tbody> <tr> <td>IIC</td> <td>NO</td> <td>2 litres or less</td> <td>Zone 1 or 2</td> <td>YES</td> </tr> <tr> <td>IIB, IIA, II</td> <td>NO</td> <td>Any</td> <td>Zone 1 or 2</td> <td>YES</td> </tr> <tr> <td>IIB, IIA, II</td> <td>YES</td> <td>Any</td> <td>Zone 2</td> <td>YES</td> </tr> <tr> <td>IIB, IIA, II</td> <td>YES</td> <td>2 litres or less</td> <td>Zone 1</td> <td>YES</td> </tr> </tbody> </table>	Gas Group?	Internal Ignition Source?	Enclosure Volume?	Which Zone?	Use Type A*LDS*F Gland?	IIC	NO	2 litres or less	Zone 1 or 2	YES	IIB, IIA, II	NO	Any	Zone 1 or 2	YES	IIB, IIA, II	YES	Any	Zone 2	YES	IIB, IIA, II	YES	2 litres or less	Zone 1	YES
	Gas Group?	Internal Ignition Source?	Enclosure Volume?	Which Zone?	Use Type A*LDS*F Gland?																					
	IIC	NO	2 litres or less	Zone 1 or 2	YES																					
	IIB, IIA, II	NO	Any	Zone 1 or 2	YES																					
	IIB, IIA, II	YES	Any	Zone 2	YES																					
IIB, IIA, II	YES	2 litres or less	Zone 1	YES																						

Interpretation of Markings. Markings on the outside of this gland carry the following meanings: **Cable Gland Type & Size A-a-LDS-b-F-ccc-ddd-IP68-nn**

a = Seal Type 2 = Neoprene (black - temp range -20° to +85°C) 3 = Silicone (white - temp range -60° to +180°C)

b = Main component material none = brass S = stainless steel A = aluminium alloy

ccc = Gland size

ddd = Entry thread type and size

IP68 = Ingress Protection code

nn = year of manufacture

Protection Concept and Gas Groups Ex d IIC / Ex e II / Ex tD A21 IP68 / Ex nR II: Ex d = Flameproof; Ex e = Increased Safety; IIC = suitable for Gas Group IIC (e.g. hydrogen) ignitable gas/air mixtures, and also Groups IIB and IIA; II = combined Gas Group; Ex tD = Ignitable dust protection by enclosure; Ex nR = Restricted Breathing

Certificate Numbers (ATEX) **SIRA 01ATEX1272X** **SIRA 09ATEX1221X**
(IEC) **IECEx SIR 07.0096X**

ATEX (EU Directive 94/9/EC) Markings  II 2 GD  II 3 GD

ATEX Special Conditions for Safe Use

- (1) These glands must not be used with Exd IIC enclosures with a volume greater than 2 litres.
- (2) These glands must not be used with enclosures where the temperature at the point of mounting exceeds -20°C to +85°C using neoprene seals, or -60° to +180°C using silicone seals.
- (3) Suitable only for fixed installations. The cable must be clamped near the gland to avoid pulling and twisting.

IEC Ex Conditions of Certification

- (1) These glands are certified with one specific size of flameproof sealing ring per gland size as supplied.
- (2) These glands must not be used with enclosures where the temperature at the point of mounting exceeds -20°C to +85°C using neoprene seals, or -60° to +180°C using silicone seals.
- (3) Suitable only for fixed installations. The cable must be clamped near the gland to avoid pulling and twisting.
- (4) The interfaces between the male thread of the products and an associated enclosure cannot be defined. Therefore it is the user's responsibility to ensure that the appropriate Ingress Protection level is maintained at these interfaces.