

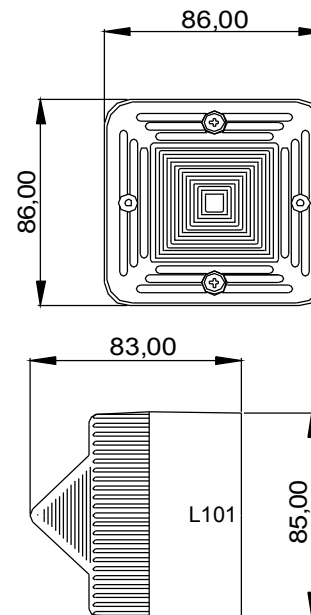

12, 24, 48vdc

L101 - L.E.D. & Bulb Beacon 'AlertAlight'

115, 230vac

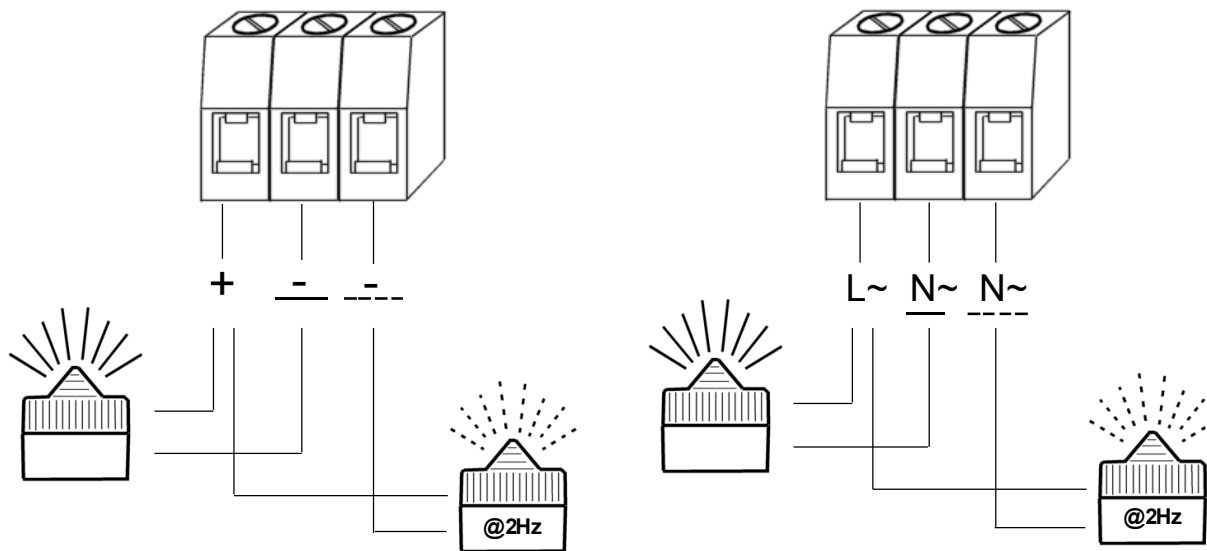

L101L : L.E.D.

Voltage :	12vdc	24vdc	48vdc	115vac	230vac	24vac
				50/60Hz	50/60Hz	50/60Hz
Voltage range :	10-14v	20-28v	42-54v	+/-10%	+/-10%	+/-10%
Current mA :	150mA	100mA	100mA	54mA	27mA	110mA

L101B : BULB

Voltage :	12vdc	24vdc	48vdc	115vac	230vac	24vac
				50/60Hz	50/60Hz	50/60Hz
Voltage range :	10-14v	20-28v	42-54v	+/-10%	+/-10%	+/-10%
Current mA :	250mA	125mA	65mA	30mA	15mA	130mA



ATTENTION

- Disconnect from power source to prevent electrical shock before installing and servicing
- Couper l'alimentation pour empêcher tout choc électrique avant d'effectuer des travaux d'installation et d'entretien.
- Vor der Installation und Wartung von der Spannungsquelle abnehmen, um elektrische Schläge zu vermeiden.
- Prima dell'installazione e della manutenzione spegnere l'alimentazione elettrica per evitare scosse elettriche.
- Desconecte la alimentación para evitar descargas eléctricas antes de la instalación y mantenimiento
- Antes de instalar ou de fazer a manutenção desligue sempre da alimentação eléctrica para evitar choques eléctricos.
- Strømmen skal afbrydes ved installering og eftersyn for at undgå elektrisk støt.
- Loskoppelen van de elektrische voeding om elektrische schok vóór installatie en onderhoud te voorkomen.
- Før montering eller vedlikehold, må spenningen koples fra for å unngå strømstøt.
- Bryt strømmen innan installation och underhåll för att förhindra elektriska stötar stötar.